

MAGNETIC DRAW WIRE SSI – PRELIMINARY



High-resolution absolute encoder based on magnetical technology without battery is combined with a draw wire as cost effective system solution for linear length measurement.

The encoder singleturn encoding is based on 360° Hall technology and Multiturn part on magnetic pulse counter.

Main Features

- Compact industrial model
- Interface: SSI (Synchronous-serial Interface)
- Code: Binary
- Housing encoder: 36.5 mm Ø
- Housing draw wire: plastic
- Encoder resolution: 4096 steps/revolution
- Min. resolution draw wire: ~ 30 µm @ 1.25 m
- EMC: EN 61000-6-2, EN 61000-6-4

Applications

- Transport systems
 - o Lifts
 - o Lifting platforms
 - o Cranes
 - o Fork lifters
- Mechanical engineering
- Testing equipment

Mechanical Structure

- Draw wire housing: plastic
- Wire coated polyamide stainless steel
- Encoder housing: Nickel-plated steel

Electrical Features

- Highly integrated circuit in SMD -technology
- Polarity inversion protection
- Over-voltage-peak protection

上海开地电子有限公司 — 德国FRABA/POSITAL (中国) 总代理

德国 FRABA 集团 版权所有

电话: 021-5268 2679 / 5268 8060 / 5268 8820 / 5268 8821

传真: 021-5268 2869

网址: www.kindele.com

MAGNETIC DRAW WIRE SSI

Technical data

Electrical data

Clock input	Via opto-coupler
Data output	Line-driver according to RS 422
Clock frequency	100 kHz - 2 MHz
Supply voltage	10-30 V DC (absolute maximum ratings) *
Turn on time	< 1 s
Power consumption	about 2 W
Electrical lifetime	> 10 ⁵ h
EMC	Emitted interference: EN 61000-6-4
	Noise immunity: EN 61000-6-2
Connection	M12 plug exit, 8 pin

* Supply voltage according to EN 50 178 (safety extra-low voltage)

Sensor data

Singleturn technology	magnetic 2 axis Hall sensor
Singleturn resolution	4096 steps / revolution (12 Bit)
Singleturn accuracy	+/-0.35° calibrated
Internal cycle time Singleturn	< 1 ms
Multiturn technology	self supplied magnetic pulse counter without battery
Multiturn resolution	can measure up to 200 Billion revolutions, limited by memory

Draw Wire data

	Cable length 1250 mm	Cable length 2100 mm
Resolution (encoder based)	30.5 µm	52.5 µm
Accuracy (encoder based)	0.12 mm	0.21 mm
Drum circumference	125 mm	215 mm
Linearity	+/- 0.02 %, +/- 0.25 mm	+/- 0.02 %, +/- 0.42 mm
Linearity valid for reverse cycles	1,000,000	1,000,000

上海开地电子有限公司 — 德国FRABA/POSITAL (中国) 总代理

德国 FRABA 集团 版权所有

电话: 021-5268 2679 / 5268 8060 / 5268 8820 / 5268 8821

传真: 021-5268 2869

网址: www.kindele.com

MAGNETIC DRAW WIRE SSI

Environmental Conditions

Operating temperature	- 20 ... + 70 °C (stationary) - 5 ... + 70 °C (flexing)
Storage temperature	- 30 ... + 70 °C
Humidity	98 % (without liquid state)
Protection Class (EN 60529)	IP 54

Mechanical data

Housing encoder	Nickel-plated iron housing	
Housing draw wire	Plastic	
Material wire	coated polyamide stainless steel	
	Cable length 1250 mm	Cable length 2100 mm
Weight	~ 200 g	~ 350 g
Wire acceleration (max)	app. 5 g	app. 5 g
Wire retraction force (min)	app. 1 N	app. 3.5 N
Wire extension force (max)	app. 1.5 N	app. 5 N
Wire diameter	0.36 mm	0.45 mm

Interface

Synchronous Serial Interface (SSI)

Driver	Driver meets EIA standard RS 422
Transfer	Transfer distance up to 1,200 m
Transmission	Balanced transmission provides high noise immunity, shielded and twisted pair lines are essential to attain extremely high noise immunity

Protocol SSI

The protocol for reading position value via single transfer is shown in upper graph. Multiple transfers is also supported, but not explained here. Detailed SSI-Interface description under www.posital.de

**MAGNETIC DRAW WIRE
SSI**

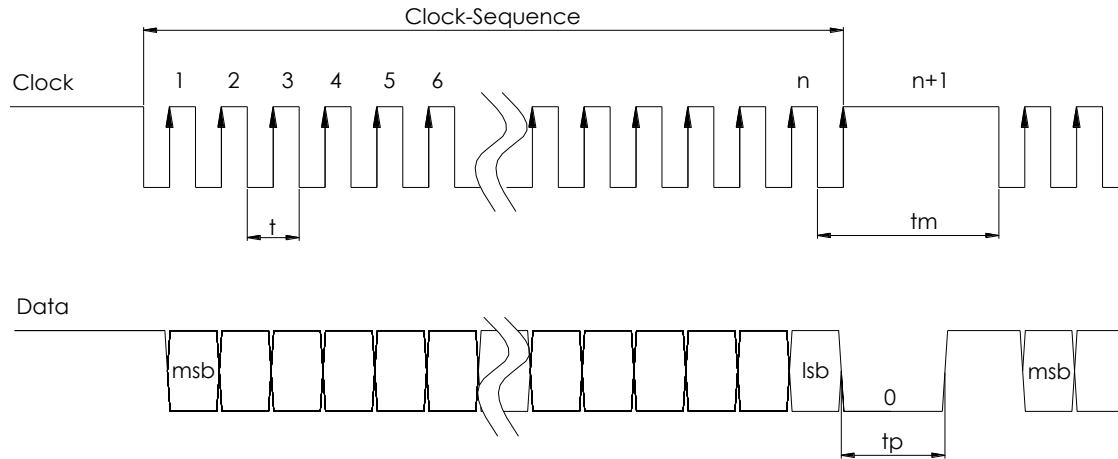

Electrical connection

The standard connection is an 8 pin circular plug M12.

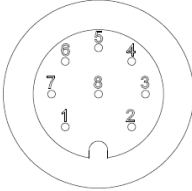
Function	Connector Pin-No.	Pinning Connector
SSI Clk-	4	(frontview) 
SSI Clk+	3	
SSI Data+	5	
SSI Data-	6	
+ U _b = 10-30 V	2	
GND	1	
Preset	7	
Complement	8	
Shielding	-	

Presetfunction

Preset Value = 0 will be set after falling edge. This function should be only used on a standstill shaft.

Voltage Level	Function
0 (Input = N.C. or GND)	inactive
1 (Input ≥ 10V / Input ≤ UB)	the encoder value will set to 0 after 1 sec
Input Resistance	10 kOhm

MAGNETIC DRAW WIRE
SSI

Complementfunction

Voltage Level	Encoder counting direction for clockwise rotation (view on shaft)
0 (Input = N.C. or GND)	Up
1 (Input $\geq 10V$ / Input $\leq UB$)	Down
Input Resistance	10 kOhm

Mechanical Drawings

Draw Wire Sensor with 1250 mm wire length

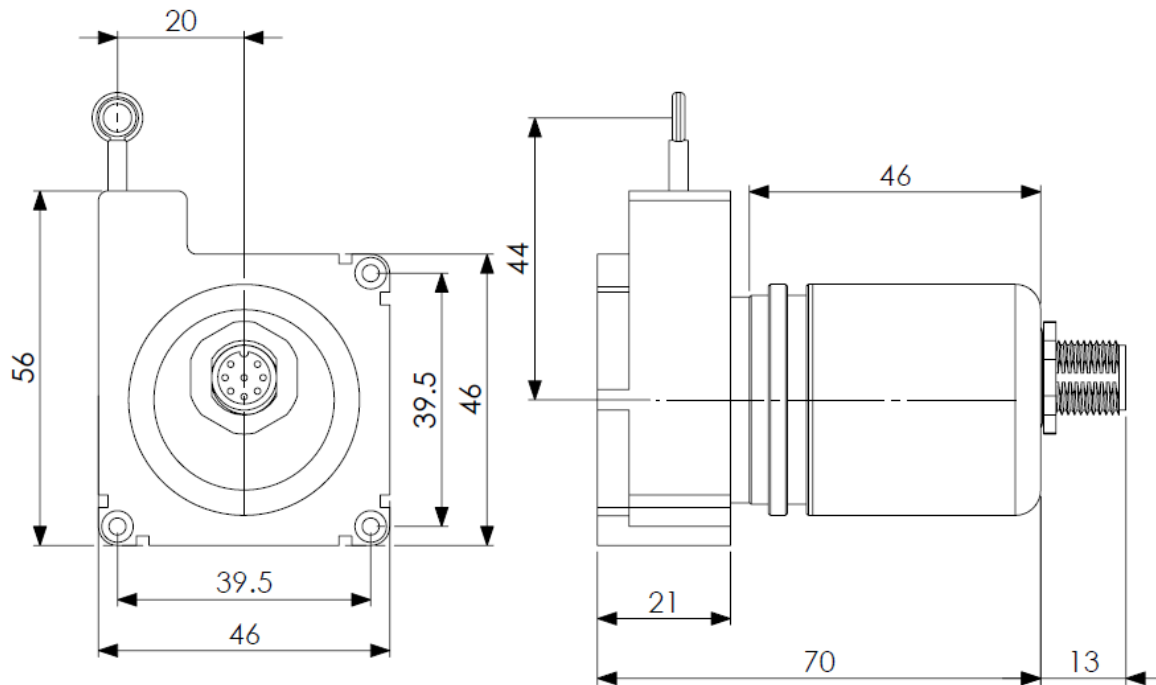

MAGNETIC DRAW WIRE
SSI

Draw Wire with 2100 mm wire length

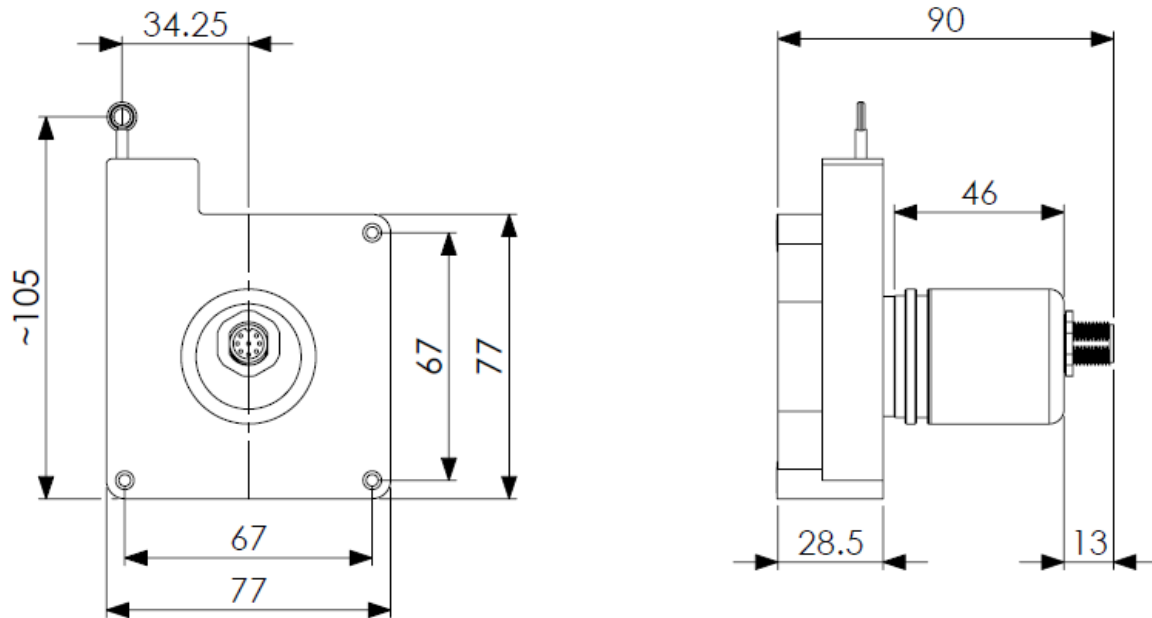

MAGNETIC DRAW WIRE SSI

Metrological Properties of the Draw Wire Sensor

Draw wire sensors measure linear movements using a highly flexible steel cable. The cable is wound around a drum, whose axis is direct jointed with the encoder. At a particular measurement object the lug of the draw wire must be mounted. With a change of distance of the measurement object to the sensor the drum rotates. This rotational movement is measured by the encoder and transmitted via a SSI interface.

Resolution

The resolution of the draw wire sensor is determined by the resolution of the encoder and of the drum circumference.

$$\text{Resolution Draw Wire Sensor} = \frac{\text{Circumference Draw Wire Sensor}}{\text{Encoder Resolution}}$$

Example:

For drum circumference see chapter draw wire data.

Encoder resolution of the encoder is 12 bit, that is 4096 steps per revolution

For a draw wire length of 1250 mm the following calculation is valid:

$$\text{Resolution Draw Wire Sensor} = \frac{125 \text{ mm}}{4096} = 30.5 \mu\text{m}$$

Accuracy (encoder related)

The accuracy of the draw wire sensor is determined by the accuracy of the encoder and the drum circumference.

$$\text{Accuracy Draw Wire Sensor} = \frac{\text{Drum circumference}}{360^\circ / \text{Accuracy Single Turn Encoder}}$$

Example:

For drum circumference see chapter draw wire data.:

Accuracy of the encoder is 0.35° per revolution.

For a draw wire length of 1250 mm the following calculation is valid:

$$\text{Accuracy Draw Wire Sensor} = \frac{125 \text{ mm}}{360^\circ / 0.35^\circ} = 0.12 \text{ mm}$$

MAGNETIC DRAW WIRE
SSI

Models / Ordering Description

Magnetic Draw Wire Sensor	MDW-	S1	00	B-	--	--	-	- P8M
Interface	SSI	S1						
Version	00		00					
Code	Binary			B				
Resolution / Wire Length	35 µm / 1250 mm				0035	0125		
	55 µm / 2100 mm				0055	0210		
Mechanical Options	Without						0	
	Customized						C	
Connection	Connector, axial, 8 pin male M12							P8M

Standard = bold, further models on request

Ordering example:

MDW-S100B-0055-0210-0-P8M

We do not assume responsibility for technical inaccuracies or omissions. Specifications are subject to change without notice.